



APEX DYNAMICS, INC.



NPV[®]
AUTOMATION . ENGINEERING . SOLUTIONS

HIGH PRECISION PLANETARY GEARBOX

AFX / AFXR Series

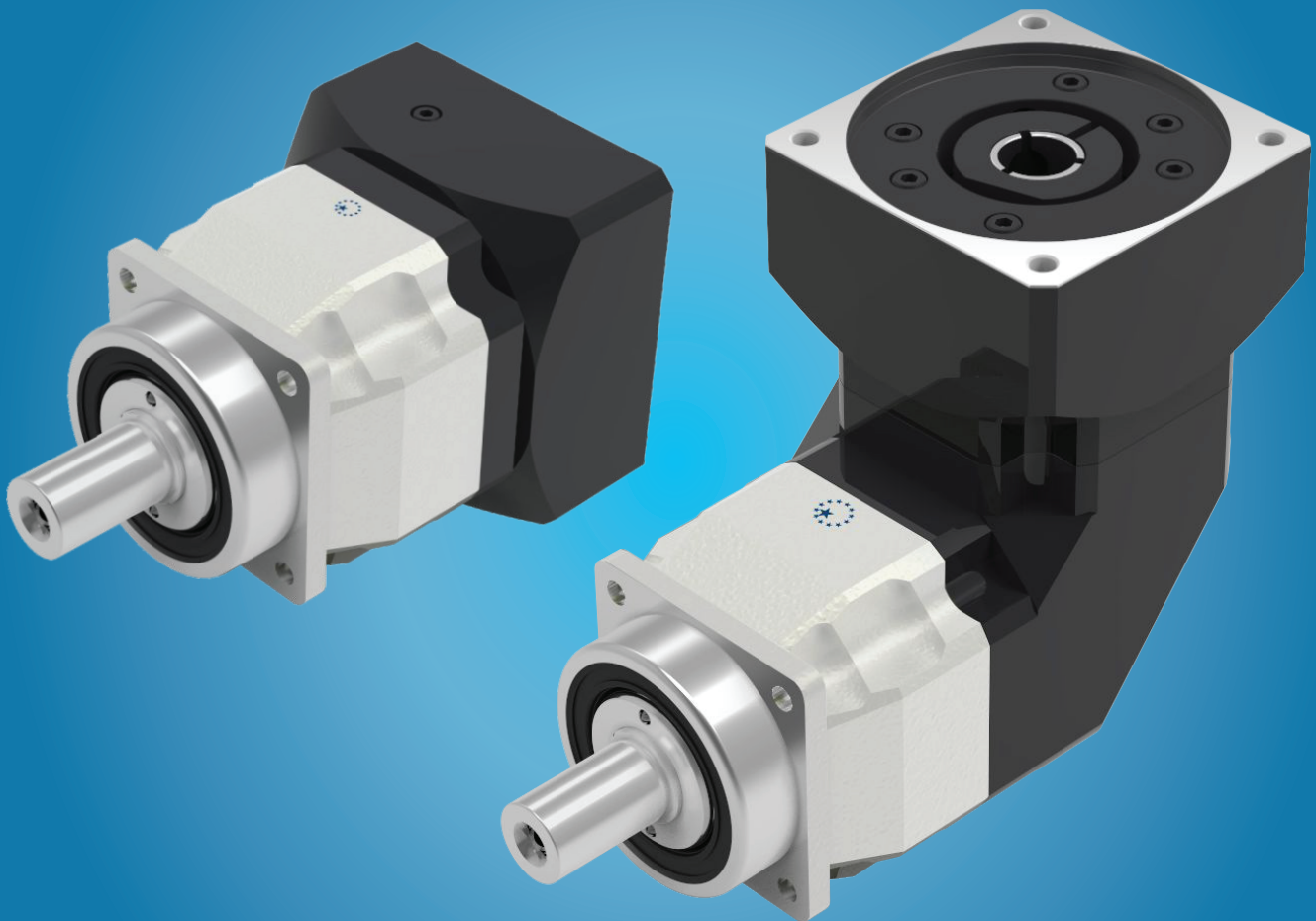

Stainless

AFX / AFXR Series

► Features:

High Torque

High Precision

Long Service Life

Low Noise

Limited Temperature Rise

More Suitable for Continuous Operation

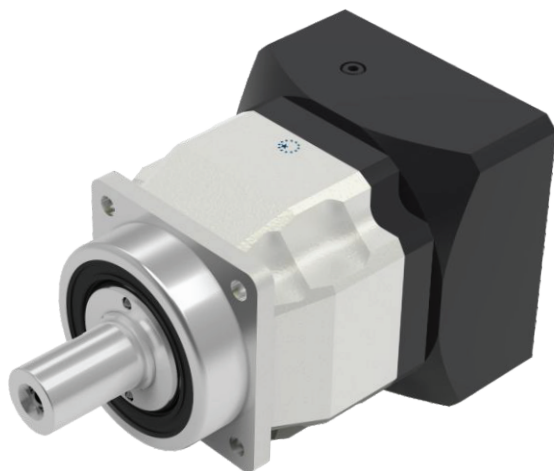

AFX

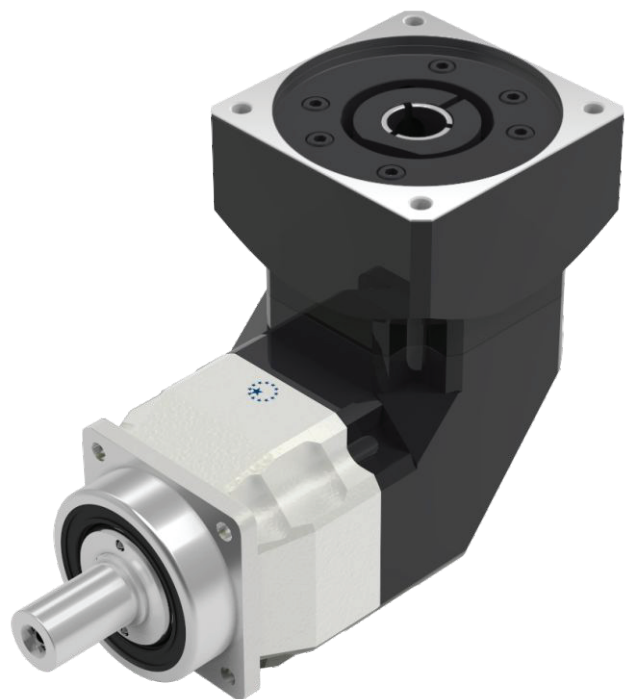

AFXR

Ordering Code - AFX / AFXR Series

AFX075	—	005⁽¹⁾	—	SI	—	PI	/	MOTOR
								Motor Type
								Backlash
								Shaft Type
								Ratio
								Gearbox Size

Gearbox Size

AFX 042 / 060 / 060A / 075 / 075A / 100 / 100A / 140 / 140A / 180

AFXR 042 / 060 / 060A / 075 / 075A / 100 / 100A / 140 / 140A / 180

Ratio⁽²⁾

AFX (1 Stg.) 3 / 4 / 5 / 6 / 7 / 8 / 9 / 10

(2 Stg.) 12 / 15 / 16 / 20 / 25 / 28 / 30 / 32 / 35 / 40 / 45 / 50 / 60 / 70 / 80 / 90 / 100

AFXR (1 Stg.) 3 / 4 / 5 / 6 / 7 / 8 / 9 / 10 / 12 / 14 / 16 / 20

(2 Stg.) 12 / 15 / 16 / 20 / 25 / 28 / 30 / 32 / 35 / 40 / 45 / 48 / 50 / 60 / 64 / 70 / 80 / 90
100 / 120 / 140 / 160 / 180 / 200

Shaft Type : S1 = Smooth Output Shaft

S2 = Output Shaft with Key

S3 = DIN 5480

Backlash : P0 = Micro Backlash

P1 = Reduced Backlash

P2 = Standard Backlash

Motor Type : Manufacturer and Model

(1) Ratio ($I = N_{in} / N_{out}$).

(2) Please refer to the specifications for the ratios provided in each series.

Specifications / AFX Series

Gearbox Performance

Model No.	Stages	Ratio ^A	AFX042 ^F	AFX060	AFX060A	AFX075	AFX075A	AFX100	AFX100A	AFX140	AFX140A	AFX180	
Nominal Output Torque T_{2N}	1	3	20	55	-	130	-	208	-	342	-	588	
		4	19	50	-	140	-	290	-	542	-	1,050	
		5	22	60	-	160	-	330	-	650	-	1,200	
		6	20	55	-	150	-	310	-	600	-	1,100	
		7	19	50	-	140	-	300	-	550	-	1,100	
		8	17	45	-	120	-	260	-	500	-	1,000	
		9	14	40	-	100	-	230	-	450	-	900	
		10	14	40	-	100	-	230	-	450	-	900	
		2	12	19	-	-	140	140	290	290	542	542	1,050
			15	20	55	55	130	130	208	208	342	342	588
	16		19	-	-	140	140	290	290	542	542	1,050	
	20		19	50	50	140	140	290	290	542	542	1,050	
	25		22	60	60	160	160	330	330	650	650	1,200	
	28		19	-	-	140	140	300	300	550	550	1,100	
	30		20	55	55	150	150	310	310	600	600	1,100	
	32		17	-	-	120	120	260	260	500	500	1,000	
	35		19	50	50	140	140	300	300	550	550	1,100	
	40		17	45	45	120	120	260	260	500	500	1,000	
	45	14	40	40	100	100	230	230	450	450	900		
	50	22	60	60	160	160	330	330	650	650	1,200		
60	20	55	55	150	150	310	310	600	600	1,100			
70	19	50	50	140	140	300	300	550	550	1,100			
80	17	45	45	120	120	260	260	500	500	1,000			
90	14	40	40	100	100	230	230	450	450	900			
100	14	40	40	100	100	230	230	450	450	900			
Emergency Stop Torque T_{2NOT} ^B	Nm	1,2	3~100	3 times of Nominal Output Torque									
Nominal Input Speed n_{IN}	rpm	1,2	3~100	5,000	5,000	5,000	4,000	4,000	4,000	4,000	3,000	3,000	3,000
Max. Input Speed n_{IB}	rpm	1,2	3~100	10,000	10,000	10,000	8,000	8,000	8,000	8,000	6,000	6,000	6,000
Micro Backlash P0	arcmin	1	3~10	-	-	-	≤1	-	≤1	-	≤1	-	≤1
		2	12~100	-	-	-	-	-	≤3	≤3	≤3	≤3	≤3
Reduced Backlash P1	arcmin	1	3~10	≤3	≤3	-	≤3	-	≤3	-	≤3	-	≤3
		2	12~100	≤5	≤5	≤5	≤5	≤5	≤5	≤5	≤5	≤5	≤5
Standard Backlash P2	arcmin	1	3~10	≤5	≤5	-	≤5	-	≤5	-	≤5	-	≤5
		2	12~100	≤7	≤7	≤7	≤7	≤7	≤7	≤7	≤7	≤7	≤7
Torsional Rigidity	Nm/arcmin	1,2	3~100	3	7	7	14	14	25	25	50	50	145
Max. Radial Load F_{2RB} ^C	N	1,2	3~100	610	2,900	2,900	4,500	4,500	7,800	7,800	9,450	9,450	15,600
Max. Axial Load F_{2aB} ^C	N	1,2	3~100	320	1,450	1,450	2,250	2,250	3,900	3,900	4,725	4,725	7,800
Max. Tilting Moment M_{2K}	Nm	1,2	3~100	20	140	140	330	330	780	780	1,210	1,210	2,340
Efficiency η	%	1	3~10	≥97%									
		2	12~100	≥94%									
Weight	kg	1	3~10	0.6	1.7	-	3.5	-	7.4	-	15.8	-	32.7
		2	12~100	0.8	2	1.5	4	4.1	9	11.3	19.1	22.5	37.6
Operating Temperature	°C	1,2	3~100	-10°C~+90°C									
Lubrication		1,2	3~100	Synthetic lubrication oils									
Degree of Gearbox Protection		1,2	3~100	IP65									
Mounting Position		1,2	3~100	all directions									
Noise ($n_f=3000$ rpm, $i=10$, No load) ^E	dB	1,2	3~100	≤56	≤58	≤60	≤60	≤63	≤63	≤65	≤65	≤67	≤67

A. Ratio ($i=N_{in}/N_{out}$)

B. Max. acceleration torque $T_{2B} = 60\%$ of T_{2NOT}

C. Applied to the output shaft center at 100 rpm

D. For continuous operation, the service life time is reduced

E. These values are measured by gearbox with ratio = 10 (1-stage) or ratio = 100 (2-stage) at 3,000 rpm no loading.

by lower ratio and / or higher RPM, the noise level could be 3 to 5 dB Higher.

F. Continuous operation is not supported.

Max. Tilting Moment M_{2K}

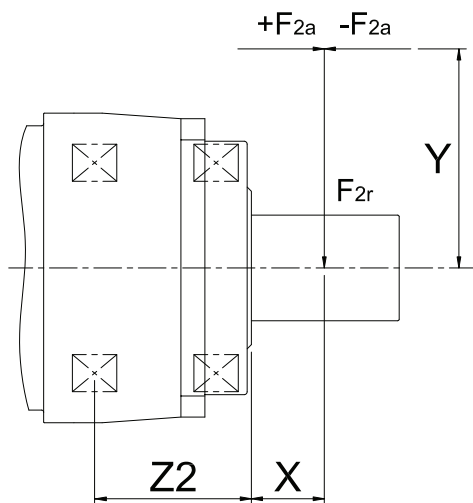

$$M_{2K} = \frac{F_{2a} * Y + F_{2r} * (X + Z2)}{1000}$$

M_{2K} : [Nm]

F_{2a}, F_{2r} : [N]

$X, Y, Z2$: [mm]

AFX / AFXR	042	060	075	100	140	180
Z2 [mm]	31	57	70	89	110	136

Note : Applied to the output flange center at 100 rpm.

For more details on F_{2a} and F_{2r} please refer to page 12.

Gearbox Inertia

Model No.	Stages	Ratio ¹	AFX042	AFX060	AFX060A	AFX075	AFX075A	AFX100	AFX100A	AFX140	AFX140A	AFX180
Mass Moments of Inertia J_i	1	3	0.03	0.16	-	0.61	-	3.25	-	9.21	-	28.98
		4	0.03	0.14	-	0.48	-	2.74	-	7.54	-	23.67
		5	0.03	0.13	-	0.47	-	2.71	-	7.42	-	23.29
		6	0.03	0.13	-	0.45	-	2.65	-	7.25	-	22.75
		7	0.03	0.13	-	0.45	-	2.62	-	7.14	-	22.48
		8	0.03	0.13	-	0.44	-	2.58	-	7.07	-	22.59
		9	0.03	0.13	-	0.44	-	2.57	-	7.04	-	22.53
		10	0.03	0.13	-	0.44	-	2.57	-	7.03	-	22.51
		12	0.03	-	-	0.16	0.61	0.61	3.25	3.25	9.21	9.21
		15	0.03	0.03	0.13	0.13	0.47	0.47	2.71	2.71	7.42	7.42
	16	0.03	-	-	0.14	0.48	0.48	2.74	2.74	7.54	7.54	
	20	0.03	0.03	0.13	0.13	0.47	0.47	2.71	2.71	7.42	7.42	
	25	0.03	0.03	0.13	0.13	0.47	0.47	2.71	2.71	7.42	7.42	
	28	0.03	-	-	0.14	0.48	0.48	2.74	2.74	7.54	7.54	
	30	0.03	0.03	0.13	0.13	0.47	0.47	2.71	2.71	7.42	7.42	
	32	0.03	-	-	0.14	0.48	0.48	2.74	2.74	7.54	7.54	
	35	0.03	0.03	0.13	0.13	0.47	0.47	2.71	2.71	7.42	7.42	
	40	0.03	0.03	0.13	0.13	0.47	0.47	2.71	2.71	7.42	7.42	
	45	0.03	0.03	0.13	0.13	0.47	0.47	2.71	2.71	7.42	7.42	
	50	0.03	0.03	0.13	0.13	0.44	0.44	2.57	2.57	7.03	7.03	
60	0.03	0.03	0.13	0.13	0.44	0.44	2.57	2.57	7.03	7.03		
70	0.03	0.03	0.13	0.13	0.44	0.44	2.57	2.57	7.03	7.03		
80	0.03	0.03	0.13	0.13	0.44	0.44	2.57	2.57	7.03	7.03		
90	0.03	0.03	0.13	0.13	0.44	0.44	2.57	2.57	7.03	7.03		
100	0.03	0.03	0.13	0.13	0.44	0.44	2.57	2.57	7.03	7.03		

Dimensions (1-stage, Ratio $i=3\sim 10$) / AFX Series

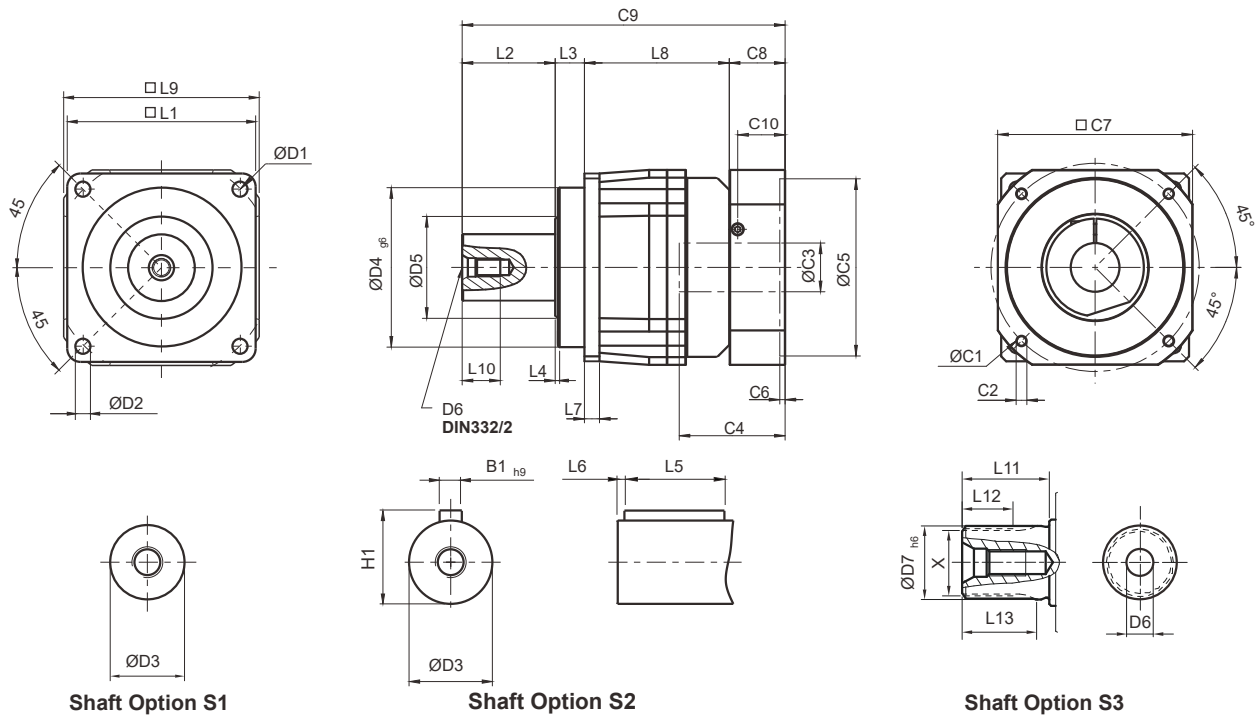

[unit: mm]

Dimension	AFX042	AFX060	AFX075	AFX100	AFX140	AFX180
D1	50	68	85	120	165	215
D2	3.4	5.5	6.8	9	11	13
D3	12 _{js}	16 _{h6}	22 _{h6}	32 _{h6}	40 _{h6}	55 _{h6}
D4 g6	35	60	70	90	130	160
D5	22	21	30	40	75	95
D6	M4 x 0.7P	M5 x 0.8P	M8 x 1.25P	M12 x 1.75P	M16 x 2P	M20 x 2.5P
D7 h6	-	16	22	32	40	55
L1	42	62	76	105	142	180
L2	19.5	28.5	36.5	58	82	82
L3	6.5	20	19.5	30	30	30
L4	1	1.5	1.5	2	3	3
L5	14	25	32	40	63	70
L6	2	2	3	5	5	6
L7	4	6	7	10	12	15
L8	31	62	84	103.5	132	180.5
L9	42	70	90	115	142	180
L10	10	12.5	19	28	36	42
L11	-	26	26	26	40	41.5
L12	-	15	15	15	20	21.5
L13	-	21	22.5	23	33.5	33.5
C1 ¹	46	70	100	130	165	215
C2 ¹	M4 x 0.7P	M5 x 0.8P	M6 x 1P	M8 x 1.25P	M10 x 1.5P	M12 x 1.75P
C3 ¹	≤11 / ≤12 ²	≤14 / ≤16 ²	≤19 / ≤24	≤32	≤38	≤48
C4 ¹	25	34	40	50	60	85
C5 ¹	30	50	80	110	130	180
C6 ¹	3.5	8	4	5	6	6
C7 ¹	42	60	90	115	142	190
C8 ¹	29.5	19	17	19.5	22.5	29
C9 ¹	86.5	129.5	157	211	266.5	321.5
C10 ¹	8.75	13.5	10.75	13	15	20.75
B1 h9	4	5	6	10	12	16
H1	13.5	18	24.5	35	43	59
X DIN5480	-	W16 x 0.8 x 30 x 18 x 6m	W22 x 1.25 x 30 x 16 x 6m	W32 x 1.25 x 30 x 24 x 6m	W40 x 2 x 30 x 18 x 6m	W55 x 2 x 30 x 26 x 6m

1. C1~C10 are motor specific dimensions (metric std shown). Refer to www.apexdyna.com and Design Tool to view your specific motor mounting system.
 2. AFX042 ratio 5, 10 offers C3 ≤ 12 option. AFX060 ratio 5, 10 offers C3 ≤ 16 option

Dimensions (2-stage, Ratio $i=12\sim 100$) / AFX Series

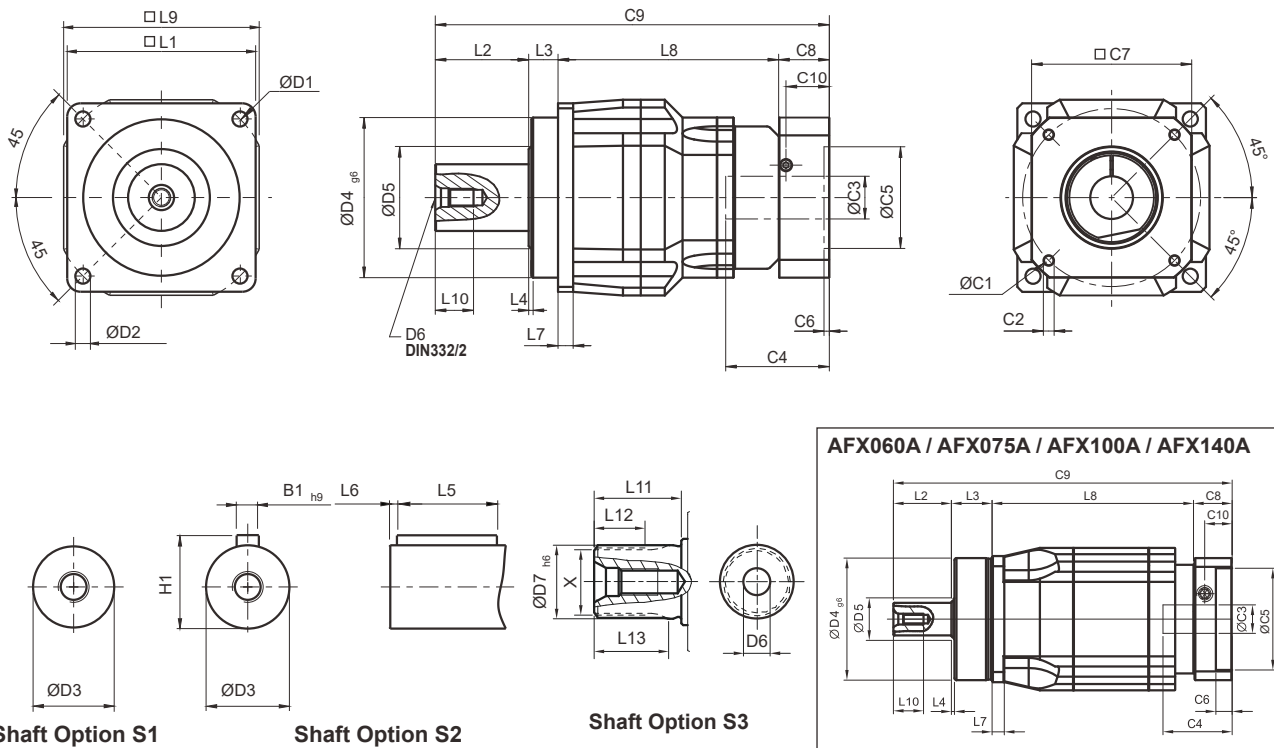

[unit: mm]

Dimension	AFX042	AFX060	AFX060A	AFX075	AFX075A	AFX100	AFX100A	AFX140	AFX140A	AFX180
D1	50	68		85		120		165		215
D2	3.4	5.5		6.8		9		11		13
D3	12 _{g6}	16 _{h6}		22 _{h6}		32 _{h6}		40 _{h6}		55 _{h6}
D4 _{g6}	35	60		70		90		130		160
D5	22	21		30		40		75		95
D6	M4 x 0.7P	M5 x 0.8P		M8 x 1.25P		M12 x 1.75P		M16 x 2P		M20 x 2.5P
D7 _{h6}	-	16		22		32		40		55
L1	42	62		76		105		142		180
L2	19.5	28.5		36.5		58		82		82
L3	6.5	20		19.5		30		30		30
L4	1	1.5		1.5		2		3		3
L5	14	25		32		40		63		70
L6	2	2		3		5		5		6
L7	4	6		7		10		12		15
L8	58.5	73	99	117	132	145	164.5	188.5	203.5	236
L9	42	70		90		115		142		180
L10	10	12.5		19		28		36		42
L11	-	26		26		26		40		41.5
L12	-	15		15		15		20		21.5
L13	-	21		22.5		23		33.5		33.5
C1 ³	46	46	70	70	100	100	130	130	165	165
C2 ³	M4 x 0.7P	M4 x 0.7P	M5 x 0.8P	M5 x 0.8P	M6 x 1P	M6 x 1P	M8 x 1.25P	M8 x 1.25P	M10 x 1.5P	M10 x 1.5P
C3 ³	≤11 / ≤12	≤11 / ≤12	≤14 / ≤16	≤14 / ≤15.875 / ≤16	≤19 / ≤24	≤19 / ≤24	≤32	≤32	≤38	≤38
C4 ³	25	25	34	34	40	40	50	50	60	60
C5 ³	30	30	50	50	80	80	110	110	130	130
C6 ³	3.5	3.5	8	8	4	4	5	5	6	6
C7 ³	42	42	60	60	90	90	115	115	142	142
C8 ³	29.5	29.5	19	19	17	17	19.5	19.5	22.5	22.5
C9 ³	114	151	166.5	192	205	250	272	320	338	370.5
C10 ³	8.75	8.75	13.5	13.5	10.75	10.75	13	13	15	15
B1 _{h9}	4	5		6		10		12		16
H1	13.5	18		24.5		35		43		59
X DIN5480	-	W16 x 0.8 x 30 x 18 x 6m		W22 x 1.25 x 30 x 16 x 6m		W32 x 1.25 x 30 x 24 x 6m		W40 x 2 x 30 x 18 x 6m		W55 x 2 x 30 x 26 x 6m

3. C1~C10 are motor specific dimensions (metric std shown). Refer to www.apexdyna.com and Design Tool to view your specific motor mounting system.

Specifications / AFXR Series

Gearbox Performance

Model No.		Stages	Ratio ^A	AFXR042 ^F	AFXR060	AFXR060A	AFXR075	AFXR075A	AFXR100	AFXR100A	AFXR140	AFXR140A	AFXR180	
Nominal Output Torque T_{2N}	Nm	1	3	9	36	-	90	-	195	-	342	-	588	
			4	12	48	-	120	-	260	-	520	-	1,040	
			5	15	60	-	150	-	325	-	650	-	1,200	
			6	18	55	-	150	-	310	-	600	-	1,100	
			7	19	50	-	140	-	300	-	550	-	1,100	
			8	17	45	-	120	-	260	-	500	-	1,000	
			9	14	40	-	100	-	230	-	450	-	900	
			10	14	40	-	150	-	325	-	650	-	1,200	
			12	-	-	-	150	-	310	-	600	-	1,100	
			14	-	42	-	140	-	300	-	550	-	1,100	
		16	-	-	-	120	-	260	-	500	-	1,000		
		20	-	40	-	100	-	230	-	450	-	900		
		2	12	12	-	-	-	-	-	-	-	-	-	-
			15	14	-	-	-	-	-	-	-	-	-	-
			16	15	-	-	-	-	-	-	-	-	-	-
			20	14	-	-	-	-	-	-	-	-	-	-
			25	15	60	60	150	150	325	325	650	650	1,200	
			28	19	-	-	140	140	300	300	550	550	1,100	
			30	20	55	55	150	150	310	310	600	600	1,100	
			32	17	-	-	120	120	260	260	500	500	1,000	
			35	19	50	50	140	140	300	300	550	550	1,100	
			40	17	45	45	120	120	260	260	500	500	1,100	
			45	14	40	40	100	100	230	230	450	450	900	
			48	-	-	-	150	150	310	310	600	600	1,100	
			50	14	60	60	100	100	230	230	650	650	1,200	
			60	20	55	55	150	150	310	310	600	600	1,100	
			64	-	-	-	120	120	260	260	500	500	1,000	
			70	19	50	50	140	140	300	300	550	550	1,100	
			80	17	45	45	120	120	260	260	500	500	1,000	
			90	14	40	40	100	100	230	230	450	450	900	
			100	14	40	60	150	150	325	325	650	650	1,200	
			120	-	-	55	150	150	310	310	600	600	1,100	
140	-	-	50	140	140	300	300	550	550	1,100				
160	-	-	45	120	120	260	260	500	500	1,000				
180	-	-	40	100	100	230	230	450	450	900				
200	-	-	40	100	100	230	230	450	450	900				
Emergency Stop Torque T_{2NOT}^B	Nm	1,2	3~200	3 times of Nominal Output Torque										
Nominal Input Speed n_{1N}	rpm	1,2	3~200	5,000	5,000	5,000	4,000	4,000	4,000	4,000	3,000	3,000	3,000	
Max. Input Speed n_{1B}	rpm	1,2	3~200	10,000	10,000	10,000	8,000	8,000	8,000	8,000	6,000	6,000	6,000	
Micro Backlash P0	arcmin	1	3~20	-	-	-	≤2	-	≤2	-	≤2	-	≤2	
		2	12~200	-	-	-	≤4	≤4	≤4	≤4	≤4	≤4	≤4	
Reduced Backlash P1	arcmin	1	3~20	≤4	≤4	-	≤4	-	≤4	-	≤4	-	≤4	
		2	12~200	≤7	≤7	≤7	≤7	≤7	≤7	≤7	≤7	≤7	≤7	
Standard Backlash P2	arcmin	1	3~20	≤6	≤6	-	≤6	-	≤6	-	≤6	-	≤6	
		2	12~200	≤9	≤9	≤9	≤9	≤9	≤9	≤9	≤9	≤9	≤9	
Torsional Rigidity	Nm/arcmin	1,2	3~200	3	7	7	14	14	25	25	50	50	145	
Max. Radial Load F_{2B}^C	N	1,2	3~200	610	2,900	2,900	4,500	4,500	7,800	7,800	9,450	9,450	15,600	
Max. Axial Load F_{2aB}^C	N	1,2	3~200	320	1,450	1,450	2,250	2,250	3,900	3,900	4,725	4,725	7,800	
Max. Tilting Moment M_{2K}	Nm	1,2	3~100	20	140	140	330	330	780	780	1,210	1,210	2,340	
Efficiency η	%	1	3~20	≥95%										
		2	12~200	≥92%										
Weight	kg	1	3~20	0.9	2.7	-	6.1	-	12.2	-	25.3	-	50.2	
		2	12~200	1.2	2.4	3.7	4.8	7.9	11.6	16	24	32	47.4	
Operating Temperature	°C	1,2	3~200	-10°C~+90°C										
Lubrication		1,2	3~200	Synthetic lubrication oils										
Degree of Gearbox Protection		1,2	3~200	IP65										
Mounting Position		1,2	3~200	all directions										
Noise ($n=3000$ rpm, $i=10$, No load) ^E	dB	1,2	3~200	≤61	≤63	≤65	≤65	≤68	≤68	≤70	≤70	≤72	≤72	

A. Ratio ($i=N_{in}/N_{out}$)

B. Max. acceleration torque $T_{2B} = 60\%$ of T_{2NOT}

C. Applied to the output shaft center at 100 rpm

D. For continuous operation, the service life time is reduced

E. These values are measured by gearbox with ratio = 10 (1-stage) or ratio = 100 (2-stage) at 3,000 rpm no loading. by lower ratio and / or higher RPM, the noise level could be 3 to 5 dB Higher.

F. Continuous operation is not supported.

Gearbox Inertia

Model No.	Stages	Ratio ^A	AFXR042	AFXR060	AFXR060A	AFXR075	AFXR075A	AFXR100	AFXR100A	AFXR140	AFXR140A	AFXR180	
Mass Moments of Inertia J _i	1	3~10	0.09	0.35	–	2.25	–	6.84	–	23.4	–	68.9	
		12~20	–	0.31	–	1.87	–	6.25	–	21.8	–	65.6	
	2	12~20	0.09	–	–	–	–	–	–	–	–	–	–
		25~90	0.09	0.09	0.35	0.35	2.25	2.25	6.84	6.84	23.4	23.4	
		48, 64	–	–	0.31	0.31	1.87	1.87	6.25	6.25	21.8	21.8	
		100	0.09	0.09	0.31	0.31	1.87	1.87	6.25	6.25	21.8	21.8	
		120~200	–	–	0.31	0.31	1.87	1.87	6.25	6.25	21.8	21.8	

Dimensions (1-stage, Ratio $i=3\sim 20$) / AFXR Series

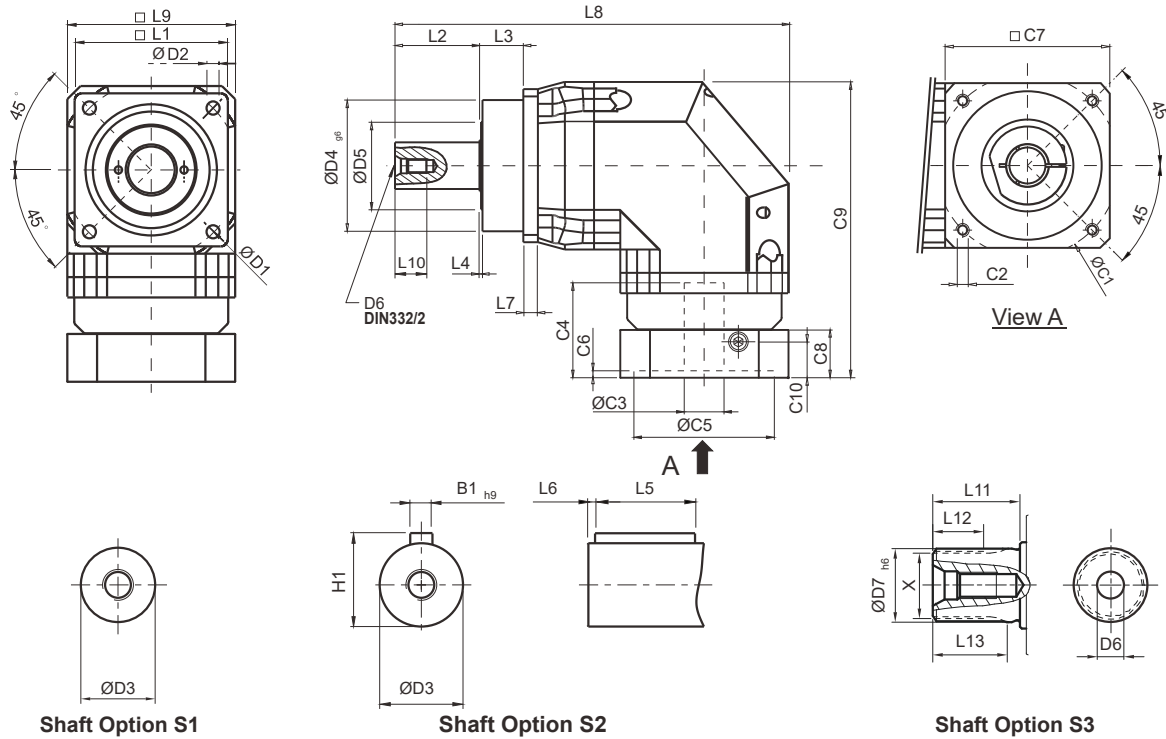

[unit: mm]

Dimension	AFXR042	AFXR060	AFXR075	AFXR100	AFXR140	AFXR180
D1	50	68	85	120	165	215
D2	3.4	5.5	6.8	9	11	13
D3	12 _{js}	16 _{h6}	22 _{h6}	32 _{h6}	40 _{h6}	55 _{h6}
D4 _{g6}	35	60	70	90	130	160
D5	22	21	30	40	75	95
D6	M4 x 0.7P	M5 x 0.8P	M8 x 1.25P	M12 x 1.75P	M16 x 2P	M20 x 2.5P
D7 _{h6}	-	16	22	32	40	55
L1	42	62	76	105	142	180
L2	19.5	28.5	36.5	58	82	82
L3	6.5	20	19.5	30	30	30
L4	1	1.5	1.5	2	3	3
L5	14	25	32	40	63	70
L6	2	2	3	5	5	6
L7	4	6	7	10	12	15
L8	111.5	171.5	216.5	283.5	360.5	427.5
L9	42	70	90	115	142	180
L10	10	12.5	19	28	36	42
L11	-	26	26	26	40	41.5
L12	-	15	15	15	20	21.5
L13	-	21	22.5	23	33.5	33.5
C1 ¹	46	70	100	130	165	215
C2 ¹	M4 x 0.7P	M5 x 0.8P	M6 x 1P	M8 x 1.25P	M10 x 1.5P	M12 x 1.75P
C3 ¹	≤11 / ≤12	≤14 / ≤16	≤19 / ≤24	≤32	≤38	≤48
C4 ¹	25	34	40	50	60	85
C5 ¹	30	50	80	110	130	180
C6 ¹	3.5	8	4	5	6	6
C7 ¹	42	60	90	115	142	190
C8 ¹	29.5	19	17	19.5	22.5	29
C9 ¹	90.5	116.5	152.5	191.5	235.5	303.5
C10 ¹	8.75	13.5	10.75	13	15	20.75
B1 _{h9}	4	5	6	10	12	16
H1	13.5	18	24.5	35	43	59
X DIN5480	-	W16 x 0.8 x 30 x 18 x 6m	W22 x 1.25 x 30 x 16 x 6m	W32 x 1.25 x 30 x 24 x 6m	W40 x 2 x 30 x 18 x 6m	W55 x 2 x 30 x 26 x 6m

1. C1~C10 are motor specific dimensions (metric std shown). Refer to www.apexdyna.com and Design Tool to view your specific motor mounting system.

Dimensions (2-stage, Ratio $i=12\sim 200$) / AFXR Series

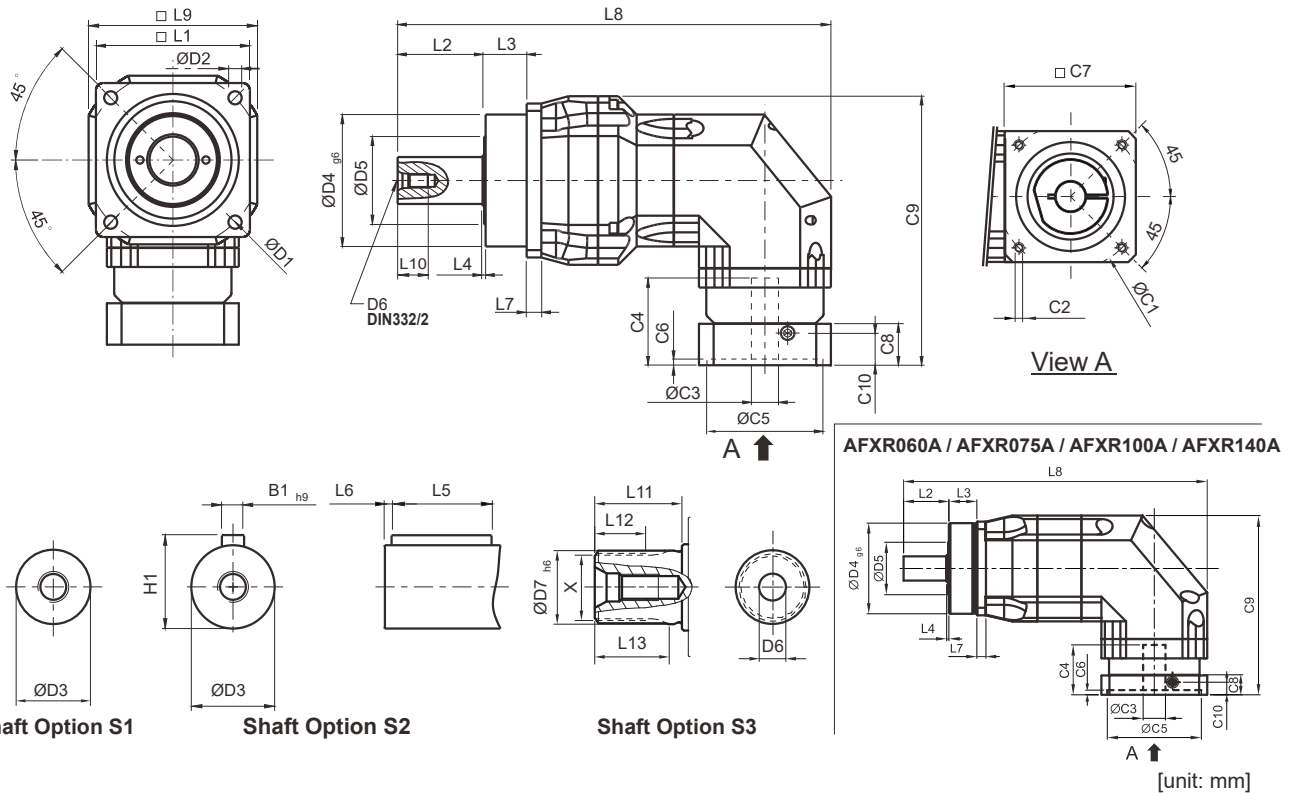

[unit: mm]

Dimension	AFXR042	AFXR060	AFXR060A	AFXR075	AFXR075A	AFXR100	AFXR100A	AFXR140	AFXR140A	AFXR180
D1	50	68		85		120		165		215
D2	3.4	5.5		6.8		9		11		13
D3	12 _{j6}	16 _{h6}		22 _{h6}		32 _{h6}		40 _{h6}		55 _{h6}
D4 _{g6}	35	60		70		90		130		160
D5	22	21		30		40		75		95
D6	M4 x 0.7P	M5 x 0.8P		M8 x 1.25P		M12 x 1.75P		M16 x 2P		M20 x 2.5P
D7 _{h6}	-	16		22		32		40		55
L1	42	62		76		105		142		180
L2	19.5	28.5		36.5		58		82		82
L3	6.5	20		19.5		30		30		30
L4	1	1.5		1.5		2		3		3
L5	14	25		32		40		63		70
L6	2	2		3		5		5		6
L7	4	6		7		10		12		15
L8	139	176	208.5	220	264.5	309.5	344.5	392.5	432	464.5
L9	42	70		90		115		142		180
L10	10	12.5		19		28		36		42
L11	-	26		26		26		40		41.5
L12	-	15		15		15		20		21.5
L13	-	21		22.5		23		33.5		33.5
C1 ²	46	46	70	70	100	100	130	130	165	165
C2 ²	M4 x 0.7P	M4 x 0.7P	M5 x 0.8P	M5 x 0.8P	M6 x 1P	M6 x 1P	M8 x 1.25P	M8 x 1.25P	M10 x 1.5P	M10 x 1.5P
C3 ²	$\leq 11 / \leq 12$	$\leq 11 / \leq 12$	$\leq 14 / \leq 16$	$\leq 14 / \leq 15.875 / \leq 16$	$\leq 19 / \leq 24$	$\leq 19 / \leq 24$	≤ 32	≤ 32	≤ 38	≤ 38
C4 ²	25	25	34	34	40	40	50	50	60	60
C5 ²	30	30	50	50	80	80	110	110	130	130
C6 ²	3.5	3.5	8	8	4	4	5	5	6	6
C7 ²	42	42	60	60	90	90	115	115	142	142
C8 ²	29.5	29.5	19	19	17	17	19.5	19.5	22.5	22.5
C9 ²	90.5	104.5	116.5	126.5	152.5	165	191.5	205	235.5	254.5
C10 ²	8.75	8.75	13.5	13.5	10.75	10.75	13	13	15	15
B1 _{h9}	4	5		6		10		12		16
H1	13.5	18		24.5		35		43		59
X DIN5480	-	W16 x 0.8 x 30 x 18 x 6m		W22 x 1.25 x 30 x 16 x 6m		W32 x 1.25 x 30 x 24 x 6m		W40 x 2 x 30 x 18 x 6m		W55 x 2 x 30 x 26 x 6m

2. C1~C10 are motor specific dimensions (metric std shown). Refer to www.apexdyna.com and Design Tool to view your specific motor mounting system.

Selection of the Optimum Gearbox

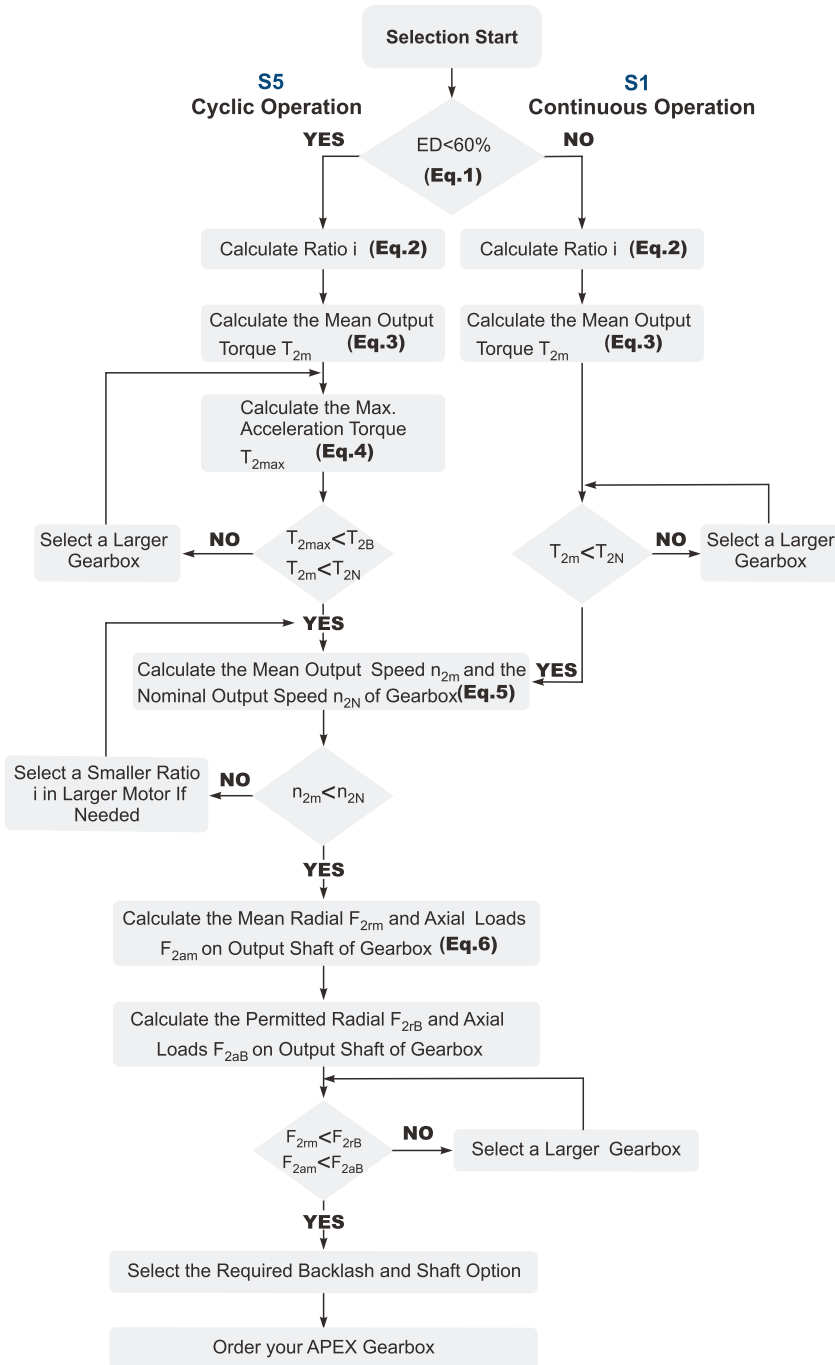

Recommended (for S5 Cycle Operation)

The general design is given for

$$\frac{J_L}{i^2} \leq 4 \times J_m$$

The optimal design is given for

$$\frac{J_L}{i^2} \cong J_m$$

J_L Load Inertia

J_m Motor Inertia

Liability Disclaimer:

APEX DYNAMICS, INC. endeavors to ensure the accuracy and reliability of the data in catalog.

APEX accepts no liability, whether in any form, for any loss or damage arising from any inaccuracy or omissions of this catalog.

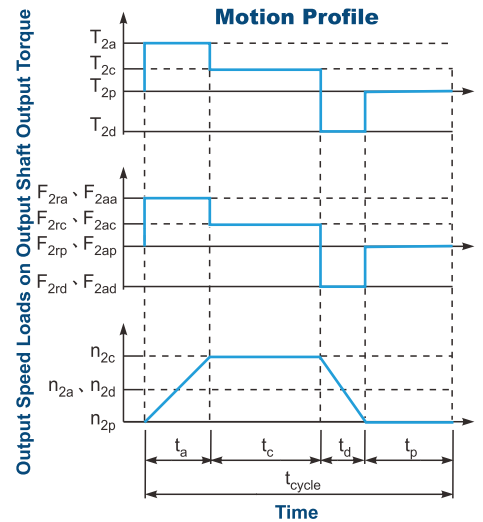

$$1. ED = \frac{t_a + t_c + t_d}{t_{cycle}} \times 100\%$$

Index : a. Acceleration, c. Constant, d. Deceleration, p. Pause

(Eq.1)

$$2. i \cong \frac{n_m}{n_{work}}$$

n_m Output Speed of the Motor

n_{work} Working Speed

(Eq.2)

$$3. T_{2m} = 3 \sqrt{\frac{n_{2a} \times t_a \times T_{2a}^3 + n_{2c} \times t_c \times T_{2c}^3 + n_{2d} \times t_d \times T_{2d}^3}{n_{2a} \times t_a + n_{2c} \times t_c + n_{2d} \times t_d}}$$

(Eq.3)

$$4. T_{2max} = T_{mB} \times i \times K_s \times \eta$$

where K_s is

K_s	No. of Cycles / hr
1.0	0 ~ 1,000
1.1	1,000 ~ 1,500
1.3	1,500 ~ 2,000
1.6	2,000 ~ 3,000
1.8	3,000 ~ 5,000

T_{mB} Max. Output Torque of the Motor

η Efficiency of the Gearbox

(Eq.4)

$$5. n_{2a} = n_{2d} = \frac{1}{2} \times n_{2c}$$

$$n_{2m} = \frac{n_{2a} \times t_a + n_{2c} \times t_c + n_{2d} \times t_d}{t_a + t_c + t_d}$$

(Eq.5)

$$6. F_{2rm} = 3 \sqrt{\frac{n_{2a} \times t_a \times F_{2ra}^3 + n_{2c} \times t_c \times F_{2rc}^3 + n_{2d} \times t_d \times F_{2rd}^3}{n_{2a} \times t_a + n_{2c} \times t_c + n_{2d} \times t_d}}$$

$$F_{2am} = 3 \sqrt{\frac{n_{2a} \times t_a \times F_{2aa}^3 + n_{2c} \times t_c \times F_{2ac}^3 + n_{2d} \times t_d \times F_{2ad}^3}{n_{2a} \times t_a + n_{2c} \times t_c + n_{2d} \times t_d}}$$

(Eq.6)

Permitted Radial and Axial Loads

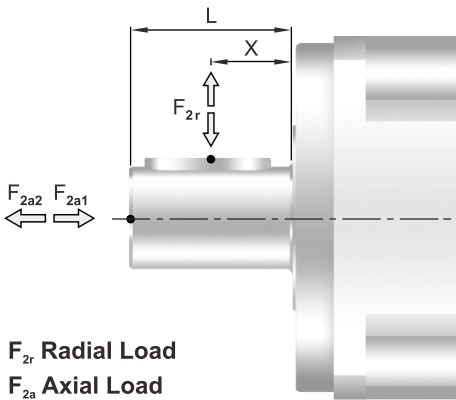

The permitted radial and axial loads on output shaft of the gearbox depend on the design of the gearbox supporting bearings. APEX use the extension straddle oversized ball bearing design. It can take heavy load from both axes.

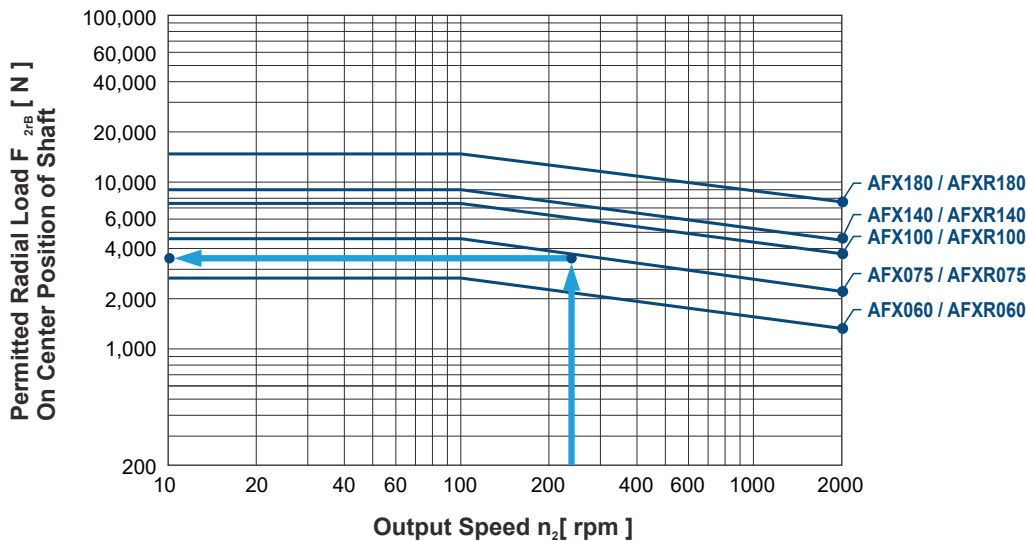

If radial force F_{2r} is exerted on the center of the output shaft $X=1/2 \times L$. Under various operating condition the lifetime is over 30,000 hours*. The permitted radial load is given on left diagram.

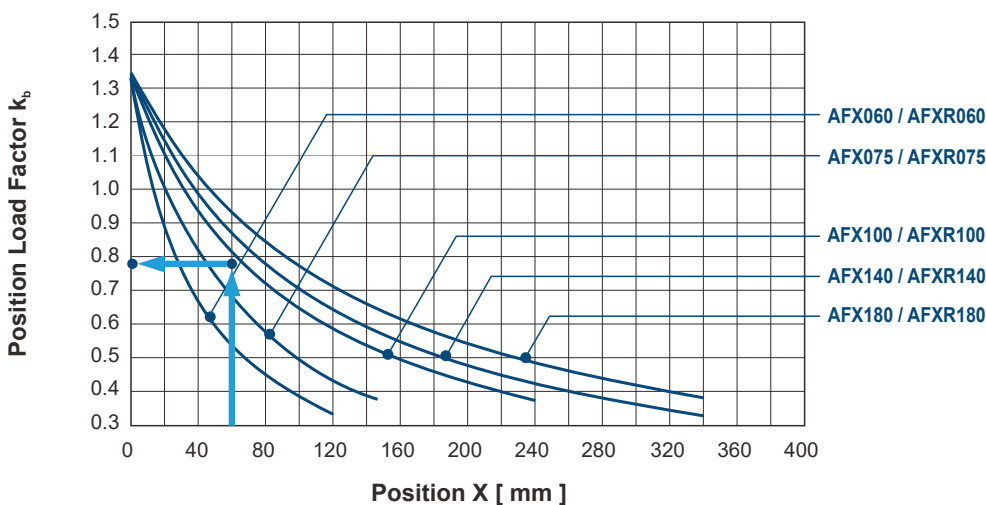

If radial force F_{2r} is not exerted on the center of the output shaft $X < 1/2 \times L$ or $X > 1/2 \times L$. The permitted radial and axial loads can be calculated by the position load factor k_b on the left diagram.

* S1 service life 15,000 hrs



NPV®

AUTOMATION . ENGINEERING . SOLUTIONS

Nam Phuong Viet Technology Jsc

Địa chỉ: 20A Phan Chu Trinh, Tân Thành, Tân Phú, Hồ Chí Minh 700000

Số điện thoại: 028 6255 8597 - 0903 803 645

Email: info@namphuongviet.vn

Website: <https://namphuongviet.vn>